

# E533–100 High Temperature Accelerometer

## Applications

- Used for vibration test on high temperature parts of aviation engine
- Adopt high temperature resistant design, balance differential structure
- Long mean time between failure (MTBF), balance differential output
- Used for vibration measurement on turbine engine

## Characteristics

- Charge sensitivity: 100pC/g
- Continuous working temperature up to +482°C
- Hermetically sealed
- Firm military standard design of connector
- Ground-isolated



Dynamic Characteristics	
Sensitivity(±5%)	100pC/g
Non-linearity	≤ 1%
Frequency response(±5%)	10 ~ 2,000Hz
Resonant frequency	12kHz
Transverse Sensitivity	≤ 1 %
Electrical Characteristics	
Excitation voltage	Passive
Resistance (Either signal pin to case)	≥ 1GΩ
+482°C	≥ 10MΩ
Insulation Resistance	≥ 100MΩ
+482°C	≥ 10MΩ
Capacitance	2300pF
Grounding	Signal return is isolated from case
Environmental characteristics	
Working temperature	-55°C ~ +482°C
Vibration limit	500 g pK
Shock limit	1000 g pK
Humidity	Hermetically sealed
Base strain Sensitivity	0.002 g pK/μ Strain
Thermal sensitivity Drift	0.03 g pK/°C
Physical characteristics	
Sensitive element	High temperature piezoelectric crystal
Output mode	Side output
Weight	≤ 110grams
Case material	INCONEL
Mounting Torque	1.6Nm

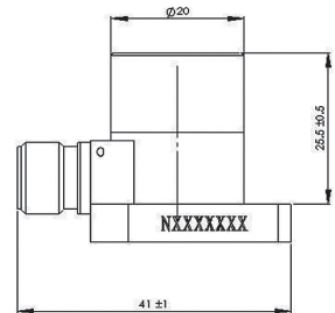
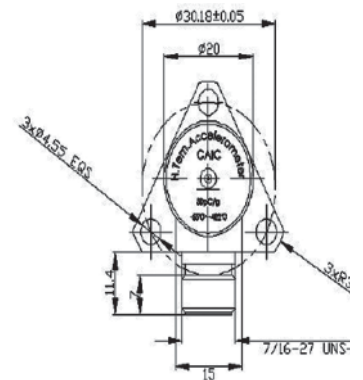

- Through the assessment of environmental test: Vibration, Shock, Acceleration, Electromagnetic compatibility, Temperature, Altitude, Temperature impact, Mould, Salt mist, Humidity and hot etc.